

BOOM

Boom	BUT 28
Feed extension	1 250 mm
Boom extension	1 250 mm
Parallel holding	complete
Feed roll-over	360°
Max. lifting angle	+65°/-30°
Max. swinging angle	±35°
Weight, boom only	1 750 kg

AIR SYSTEM

Electronically driven piston compressor	Atlas Copco LE3
Capacity, max at 7 bar	4.4 l/s
Air pressure gauge	

WATER SYSTEM

Water booster pump	Flygt PXR411H
Water booster pump max capacity at 12 bar, l/s	1.1
Min water inlet pressure, bar	2
Water flow guard	

ELECTRICAL SYSTEM

Total installed power	63 kW
Main motors	1 x 55 kW
Voltage	380-1 000 V
Frequency	50-60 Hz
Starting method	star/delta (1 000 V direct start)
Thermal overload protection for electric motors	
Percussion hour meter	
Digital voltmeter/amperage meter in electric cabinet	
Phase sequence indicator	
Earth fault indicator	
Battery charger	
Transformer	1.5 kVA
Cable reel, diameter	1 100 mm

HYDRAULIC SYSTEM

Hydraulic pumps	1 unit
Pumps unloaded at start	
System pressure, max	150-230 bar
Hydraulic oil tank, volume max	124 l
Oil temperature meter	
Manual oil filling pump	
Oil filter indicator	
Low oil level indicator	
Water cooled oil	
Filtration	20 µm
Mineral hydraulic oil	

CARRIER

Deutz 5-cylinder, F5L 912W diesel engine	
Power rating at 2 300 rpm	52 kW (75 hp)
Torque at 1 550 rpm	230 Nm
Articulated steering	±41° steering angle
Fixed seat for tramming	
Four-wheel drive	
Articulated steering	
Hydrostatic transmission	Clark 12000
Front axle	Dana 112
Rear axle	Dana 112, ±10° oscillation
Automatic differential, limited slip 45% rear axle	
Tyres	8.25 x R15
Clearance outside axles	15°
Hydraulic jacks, front	2 extendable
Hydraulic jacks, rear	2
Service brakes	2 separate circuits
Emergency and parking brakes	SAHR
Fuel tank, volume	60 l
Exhaust catalyser	
Silencer	
Electric system	24 V
Batteries	2 x 12 W, 70 Ah
Tramming lights	8 x 70 W, 24 V
Working lights	2 x 500 W, 230 VAC
Brake lights	
Fire extinguisher	
Central lubrication system	
Spirit level	
Gradeability at max. load on drive wheels	1:4
Horn, beacon and reverse alarm	
Rock drill lubrication warning kit	

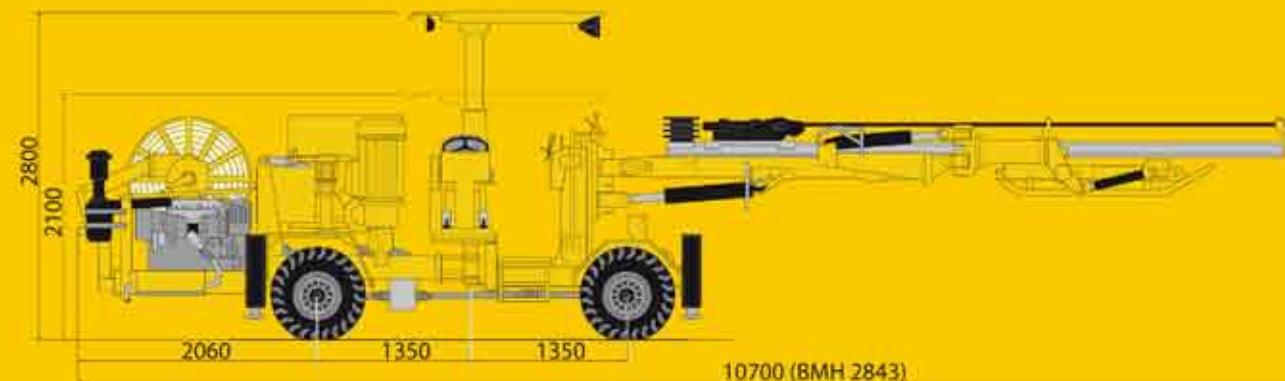

SIDE VIEW

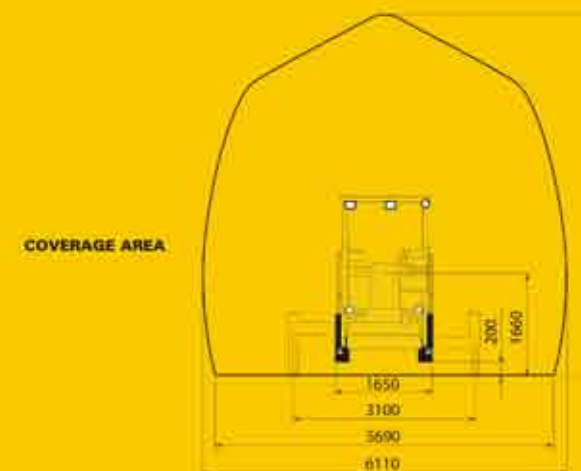

COVERAGE AREA

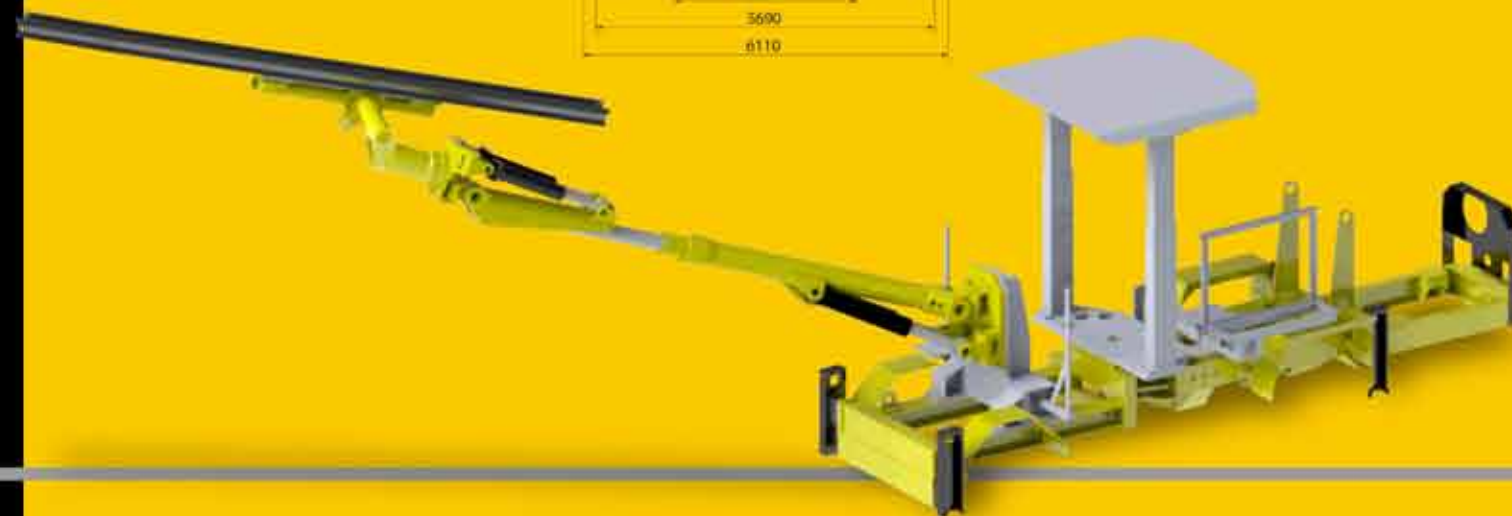

MAQDrill



Los Canelos #137
San Bernardo
Santiago - Chile
Fono / Fax: (56 - 2) 857 54 09
e-mail: rquero@maqmining.cl

